

Switchboard Case option



Socket Mount model

## Intelligent Revenue Meters

Used to monitor electric power networks, service entrances and substations, the ION 8000™ series are the world's most advanced socket-based energy meters, providing high accuracy metering with a wide range of capabilities.

The ION 8000 series meters give you the tools to manage complex energy supply contracts that include commitments to power quality. Integrate them with our ION Enterprise™ operations software or other energy management and SCADA systems through multiple communication channels and protocols including MV90.

ION 8000 series meters with the Extended Current Range option are ideal for independent power producers and co-generation applications that need to accurately measure energy bi-directionally in both generation and stand-by modes.

Patented ION® technology lets you customize metering or analysis functions at your workstation, without any hard-wiring. Just graphically link a few drag-and-drop icons, or select default setups, and you're ready to go.

***Not all features listed are available with every model. Please refer to the detailed descriptions within, for a complete list of feature availability.***

† Available only on ION 8400 and ION 85000

\* Available only on ION 8500

## Applications Summary

### Revenue Metering

Monitor compliance with energy supply contracts. Energy suppliers can offer customized rates, flexible billing, transformer/line loss compensation, and web-based reporting. Energy consumers can audit their power requirements and confirm their bills.

### Co-generation and IPP Monitoring

Use the Extended Current Range option to monitor bidirectional flow for both generation and stand-by modes.

### Compliance Monitoring

Monitor compliance with international flicker and harmonics standards, IEC 61000-4-7 / 4-15.

### Power Quality Analysis

Use the meters to measure percentage of system up-time in nines (i.e. 99.9% up-time). Find the cause of transients, harmonics and sags. Analyze problems and avoid repeat interruptions.

### Demand and Power Factor Control

Avoid penalties with automated load shedding, scheduling, peak shaving or capacitor bank control.

### Load Curtailment

Implement load curtailment and distributed generation strategies.

### Equipment Monitoring and Control

Base your maintenance schedule on actual operating history. Meter all your utilities including gas, steam, water and more.

### Energy Pulsing and Totalization

Use digital I/O for KYZ pulsing, end-of-interval and totalization.

### Instrument Transformer Correction

Use the meter's ITC feature to correct for less accurate transformers, saving money and improving accuracy.

## Features Summary

### Measurements

- ◆ Advanced, high accuracy revenue metering
- ◆ True RMS 3-phase voltage, current and power
- ◆ Harmonics, K-Factor, symmetrical components, sag/swell

### Internet-Enabled Communications

- ◆ Supports ION, Modbus, DNP 3.0 protocols
- ◆ Compatible with Itron MV-90® software
- ◆ Two RS-485 ports, one switchable to RS-232
- ◆ One front panel optical port
- ◆ Optional built-in modem with ModemGate™ allows modem access to RS-485 devices
- ◆ Optional Ethernet port with EtherGate™ allows network access to RS-485 device networks
- ◆ Access meter data through web browser, with user-configurable web pages
- ◆ GPS synchronization of meter clock
- ◆ Remote alarm notification and log receipt

### On-Board Data Logging

- ◆ Waveform and fault recording, plus transient detection up to 65us at 60Hz\*
- ◆ Sequence-of-events and min/max logging
- ◆ Scheduled or event-driven logging of up to 800 parameters concurrently\*

### Setpoints for Control and Alarms

- ◆ Setpoint on any parameter or condition
- ◆ 1 second and half-cycle† operation
- ◆ Outage dial-back capability

### Optional Digital Inputs/Outputs

- ◆ 4 KYZ digital outputs and 3 Form A digital inputs, under glass
- ◆ 8 digital inputs for status/counter functions, 8 solid state relay outputs for control/pulse functions, and 4 analog outputs through external I/O expander
- ◆ Pluggable connection for serial RS232 communications



**POWER  
MEASUREMENT**

smart energy everywhere™

# Datasheet: ION<sup>®</sup> 8300 | 8400 | 8500

## Energy Display

<b>kWh deliver</b>	<b>00000004.460</b>
<b>kWh receive</b>	<b>00000000.000</b>
16:02:06 10/11/2003 A CB Q1 NORM <span style="display: inline-block; width: 10px; height: 10px; background-color: black;"></span> 12m	

## Peak demand with date and time-stamp

kW block peak deliver	000001
01/01/2004 18:00:00	
kVA block peak deliver	000001
01/01/2004 18:00:00	
kVAR block peak deliver	000001
01/01/2004 18:00:00	
16:53:26 10/22/2003 A B C Q1 NORM <span style="display: inline-block; width: 10px; height: 10px; background-color: black;"></span> 6:34m	

## View Time-Of-Use data via the front panel

kWh del A	<b>283.4 kWh</b>
kWh del B	<b>372.6 kWh</b>
kWh del C	<b>476.8 kWh</b>

The meters display system reliability in nines, (i.e. 99.9% up-time).

<b>Availability-ppm</b>	<b>999831.30</b>
<b>No. of 'Nines'</b>	<b>3.00</b>
<b>EvalTime (days)</b>	<b>38.15</b>
23:03:29 11/14/2003 A B C Q1 NORM <span style="display: inline-block; width: 10px; height: 10px; background-color: black;"></span> 11m	

Built-in Web server provides browser access to extensive real-time meter data†

Real-Time Data		Revenue Measurements	
<b>Voltage</b>			
V <sub>ln</sub> avg	352.46 V	<b>Current</b>	
V <sub>ln</sub> a	218.43 V	I avg	208.8
V <sub>ln</sub> b	366.75 V	I a	198.0
V <sub>ln</sub> c	472.19 V	I b	200.3
V <sub>ll</sub> avg	577.64 V	I c	227.9
V <sub>ll</sub> a-b	581.88 V	I <sub>2</sub>	0.00
V <sub>ll</sub> b-c	579.24 V	I <sub>unbal</sub>	9.18†
V <sub>ll</sub> c-a	571.80 V	<b>Power Factor</b>	
V <sub>ll</sub>	53.52 V	PF sign total	-92.5
V unbal	38.03 %	PF sign a	-68.7
<b>Frequency</b>			
PF sign b			

## Front Panel Display

ION 8000 series meters have a bright, easy-to-read, backlit LCD display screen with adjustable contrast that can be used to configure meter settings or view power system data. The front panel displays all metered values, any of 31 pre-configured data display screens including phasor diagrams and harmonics histograms, as well as screens that you have customized.

## Revenue Metering

Energy  
ION 8000 series meters offer revenue approved, fully bi-directional measurements, and monitor energy in all four quadrants. The meters provide all traditional active, reactive and apparent energy parameters, and can also be configured to integrate any instantaneous power parameter to provide measurements like Volt-Hours, Amp-Hours, etc. Energy registers can be logged automatically or on a programmed schedule.

- kWh (delivered and received)
- kWh, kVARh and kVAh net (delivered - received)
- kWh, kVARh and kVAh total (delivered + received)
- kVARh, kVAh delivered and received
- Volt-hours, Amp-hours and KQ-hours
- Integration of any instantaneous measurement

## Demand

ION 8000 series meters support all standard demand calculation methods, including block, rolling block, thermal (exponential), and predicted demand. The meters can measure demand on any instantaneous value and record peak (maximum) and minimum demand with date and time stamps to the second. Peak demand registers can be reset manually (password protected) or logged and reset automatically on a programmed schedule. Measurements include:

- kW, kVAR and kVA demand, min/max
- Volts and Amps demand, min/max
- KQ and Cumulative Demand
- Demand on any instantaneous measurement

## Time-Of-Use

ION 8000 series meters provide comprehensive time-of-use (TOU) metering, configurable in accordance with virtually any utility tariff structure. TOU register values can be recorded automatically, at user-specified time intervals, at pre-scheduled dates and times, or when internal or external events occur. Registers can be reset manually (password protected) or on a pre-programmed schedule. Measurements include:

- Active, reactive and apparent energy TOU
- Active, reactive and apparent demand TOU
- Automatic recording of maximum (peak) demand during each tariff period
- 20 year calendar with automatic leap-year and daylight savings time adjustment

- Calendar supports division into 4 seasons
- Supports 5 daily profiles per season
- Supports 4 rate periods per daily profile
- Automatic mid-season rate change support

## Instantaneous

ION 8000 series meters provide a choice of high-accuracy 1 second or high-speed 1/2 cycle† measurements, including true RMS, per phase and total for:

- Voltage and current
- Active power (kW) and reactive power (kVAR)
- Apparent power (kVA)
- Power factor and frequency
- Neutral current on form 39S, 76S meters†
- Voltage and current unbalance
- Phase reversal

## Transformer and Line Loss Compensation

- Flexible compensation methods
- Easy configuration
- Updated every second
- Available through all supported protocols

## Instrument Transformer Correction

The meters provide high-accuracy instrument transformer correction, allowing you to use lower-accuracy, lower-cost transformers while retaining high-accuracy transformer function.

## Accuracy and Approvals

- Independent certification to C12.20-1998, class 0.2 by MET Labs
- Independent certification to IEC 60687 - Class 0.2S by KEMA
- Industry Canada Approval (AE-0924)
- US approvals include California ISO, ERCOT and New York State
- Certified by Comision Federal de Electricidad and LAPEM in Mexico, and INTI in Argentina

## Power Quality Metering

### Compliance Monitoring\*

- IEC 61000-4-7 harmonics and inter-harmonics\*\*
- IEC 61000-4-15 flicker
- CBEMA/ITIC

The meters can also be configured to monitor:

- EN50160
- IEEE 519 and IEEE 1159

### Waveform Recording\*

The ION 8500 can simultaneously capture all voltage and current channels.

- Sub-cycle disturbance capture
- The maximum number of cycles for contiguous waveform capture is 92,000 (based on 16 samples/cycle x 96 cycles)

- Up to 256 samples/cycle
- Dynamic range: Voltage inputs - 14 bits effective;  
Current inputs - 18 bits effective

### Measure Up-time Using Nines

The current electricity supply infrastructure can typically provide electricity with 99.9% reliability (3 nines or 8.8 hours downtime a year). However, any disruption is unacceptable for businesses in the digital economy that can require up to 99.9999999%, (9 nines or 2 cycles downtime) to effectively run their business model. Measure the number of nines of reliability with the ION 8000 series meters.

### Out-of-Limit Detection

Detect, record, and report the specifics of voltage or current imbalances and loss, frequency/power factor variations, over and undervoltages, etc.

### Harmonic Distortion Metering

The ION 8300 meters present harmonic distortion to the 31<sup>st</sup>, the ION 8400 to the 63<sup>rd</sup> and the ION 8500 to the 127<sup>th</sup> (via ION Enterprise operations software), for voltage, current and neutral inputs.

- Individual to the 40<sup>th</sup> (including magnitude, phase and inter-harmonics for the ION 8500)
- Total even or total odd harmonics
- Total harmonics (even + odd)
- K-factor, Crest factor

### Sag/Swell Detection

The meters offer a sag/swell capture capability that can be used to analyze the severity and potential impact of sags and swells.

- Magnitude and duration data suitable for plotting on voltage tolerance curves
- Excess or deficient energy during the event<sup>†</sup>
- Per phase triggers for waveform recording\* or control operations
- Sag/swell analysis with our ION Enterprise<sup>®</sup> operations software
- Captures outage duration and voltage level throughout a true 3-phase outage

### Transient Capture\*

Detect and record sub-cycle transients as short as 65us at 60Hz (78us at 50Hz).

### Symmetrical Components Metering

The meters measure zero, positive, and negative sequence components for voltage and current. Calculation of phase unbalances using symmetrical components can also be performed.

### Outage Dial-back

When equipped with the outage dial-back option, an ION 8000 series meter can notify a pager or MV-90 when control power is disrupted.

## Data and Event Recording

The ION 8500 is equipped with 4 MB of meter-based nonvolatile memory for historical data storage, the ION 8400 has 2 MB and the ION 8300 has 1 MB.

### Traditional Load Profiling

The ION 8500 incorporates 800 channels via 50 data recorders, the ION 8400 is equipped with 320 channels via 20 recorders, and the ION 8300 offers 32 channels via 2 data recorders. Channel assignments are user-configurable for historical trend recording of energy, demand, voltage, current, power quality, or any other measured parameter. Recorders can be triggered on a time interval basis, on a calendar schedule, by an alarm/event condition, or manually.

### High-Speed Data Recording<sup>†</sup>

The ION 8400 and ION 8500 meters feature high-speed "burst" recording (as fast as 1/2-cycle intervals) to store detailed disturbance or outage characteristics. Recording can be triggered by a user-defined setpoint, or from external equipment. Gated recording logs data only during the critical event so that memory is conserved.

### Coincident Min/Max Recording

Configure the meters to record the values of key parameters or equipment conditions coincident with an extreme condition, complete with date/time stamping to the millisecond. For example, record all feeder voltages and currents at the moment a peak demand condition occurs.

### Event Recording

Events, sequence-of-events, and alarm conditions are recorded and date/time-stamped to millisecond resolution. Record the details of power quality events, including magnitudes, durations, and equipment status. Use information from multiple GPS equipped meters to correlate system-wide events and equipment operation.

### Time Synchronization and GPS

The meters have real-time clocks that allow data records and internal events to be dated and timestamped within milliseconds.

Synchronize them to:

- The meter's internal crystal (+/- 12 ppm typical)
- The line frequency of the electrical network being metered (+/- 10ppm)
- External ASCII or IRIG-B GPS receiver with +/- 1ms accuracy

3-phase and average voltage

Vln a	120.00 V
Vln b	119.91 V
Vln c	119.89 V
Vln avg	119.93 V
20:57:09 10/11/2003 A B C Q1 ALT 2:51m	

3-phase and neutral current

I a	3.750 A
I b	4.999 A
I c	4.252 A
I avg	4.334 A
21:00:47 10/11/2003 A B C Q1 ALT 14m	

Displays a complete range of power parameters

kW total	1.44
kVAR total	0.60
kVA total	1.56
PF sign total	92.36 LG
21:02:12 10/11/2003 A B C Q1 ALT 12m	

Unique vector diagram with magnitude and phase angle can help reduce installation time

VB	IB	VA	119.92V	0.0
VC	IC	VB	119.83V	120.7
VA	IA	VC	119.85V	240.6
VB	IB	IA	3.745A	310.1
VC	IC	IB	4.994A	70.9
		IC	4.247A	192.5
21:03:22 10/11/2003 A B C Q1 ALT 11m				

View THD and individual harmonics through the front panel display screen

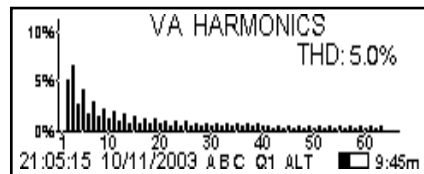

# Datasheet: ION® 8300 | 8400 | 8500

## Logic, Math and Control

The meters can perform on-board calculations for any measured value. Calculate true quantities from pulse inputs (e.g. BTU calculations). You can also implement real-time billing schemes.

### Mathematical Functions

Customize formulas using the following operators:

- ♦ Arithmetic (+, x, -, ÷)
- ♦ Comparison (>, <, =, ≥, ≤, ≠)
- ♦ Logical (AND, OR, NOT, TRUE, FALSE, IF)
- ♦ Trigonometric (SIN, COS, TAN, ASIN, ACOS, ATAN)
- ♦ Math (PI, SQRT, POWER, SUM, SUMSQ, AVG, RMS, LOG10, LN, MAX, MIN)

### Programmable Logic and Setpoints

The meters offer 65 setpoints configurable for 1-second or 1/2-cycle<sup>†</sup> operation. Use them to trigger:

- ♦ Audible and visible alarms
- ♦ Modem/pager dial-back
- ♦ Data logging
- ♦ Waveform recording\*
- ♦ Relays
- ♦ Clearing and reset functions
- ♦ Relative setpoints

## Modbus Master

The ION 8400 and ION 8500 meters can both read and write data to Modbus slave devices. This powerful feature lets ION meters collect data from a Modbus network, process it, then deliver the information through any of the meter's communication channels.

Modbus master read capability lets you perform detailed sub-metering using low-cost instruments (like our ION 6200 or other Modbus slave devices). The meters can use the data from the Modbus network for recording, trending, alarming and will also display parameters like energy, reactive energy, power factor, frequency, voltage unbalance etc. Modbus master write capability allows control commands or data to be sent directly to Modbus slave devices (e.g. control I/O points, reset parameters, etc.).

Modbus mastering allows for detailed facility monitoring so you can achieve a better understanding of where inefficiencies are located, and develop strategic load shedding applications.

## Internet Connectivity

### MeterM@il®

An Ethernet port enables automatic e-mail alarm notifications or scheduled system-status updates. MeterM@il messages can be received like any e-mail message, at a workstation, cell phone, pager or PDA. Data logs can also be sent on an event-driven or scheduled basis via e-mail, while conveniently accommodating firewall restrictions.

### WebMeter™

An on-board Web server offers quick and easy access to real-time values and basic power quality information without special software. Built-in, user-configurable web pages display a range of energy and basic power quality information through web-enabled devices and even supports basic meter configuration.

## XML Compatibility

The meters can also exchange information using the industry-standard XML format. Its simple machine readable-format supports easy integration with custom reporting, spreadsheet, database and other applications.

## Communications

### Multi-Port, Multi-Protocol Access

The meters offer multi-port access that provides secure, simultaneous data sharing with utility systems and customers directly at the hardware level using a choice of communication standards and protocols.

### Serial Ports

1 RS-232/485 and 1 additional RS-485 port depending on the ordering options selected.\*

- ♦ Protocols: ION, DNP 3.0, Modbus RTU, GPS
- ♦ Baud rate: (RS-232) 300bps to 115,200bps (RS-485) 300bps to 57,600bps

### Infrared Data Port

Front panel ANSI C12.13 Type 2.

- ♦ Protocols: ION, Modbus RTU, DNP 3.0
- ♦ Baud rate: Up to 19,200bps

### Internal Modem

Available internal telephone modem features fast connect and ModemGate™, a gateway letting up to 31 additional devices share a meter's internal modem through a serial port.

- ♦ Protocols: ION, Modbus RTU, DNP 3.0
- ♦ Baud rate: Up to 33.6kbps

### Ethernet Port

Optional 10Base-T or 10Base-FL port offers direct access through an Ethernet LAN/WAN and features EtherGate™, which permits the direct transfer of data between an Ethernet network and up to 31 devices via the meter's serial ports.

- ♦ Protocols: TCP/IP, ION, Modbus TCP
- ♦ Speed: 10Mbps

### IRIG-B Port

Optional link to synchronize internal clock to a GPS receiver. The meter accepts unmodulated IRIG-B time code data.

### Itron Software Support

The meters are fully compatible with Itron software platforms including MV-90®, MVP, MVLT and MVCOMM. Our ION 8000 series are the only socket meters with a direct Ethernet connection to MV-90.

### Flash Memory-Based Firmware

- ♦ Perform upgrades via communications without removing the meter from the site
- ♦ Easily add new ION modules and features as they become available\*\*

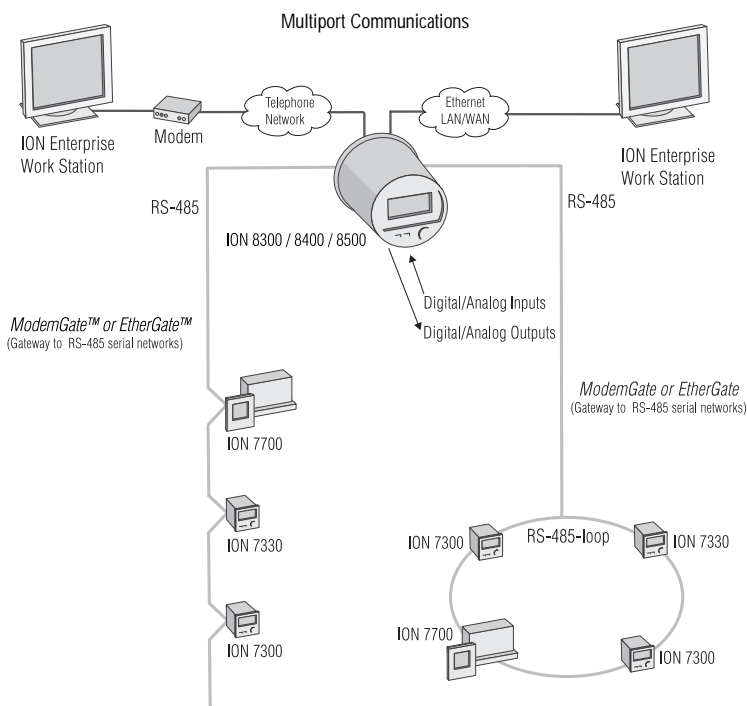



# Datasheet: ION® 8300 | 8400 | 8500

## Inputs/Outputs

ION 8000 series meters can be ordered with optional built-in I/O comprised of 4 KYZ digital outputs and 3 Form A digital inputs.

An optional external I/O Expander provides additional I/O capabilities and standard serial port connections for the meters. The I/O Expander offers an easy connection to external equipment and a physical interface for energy management systems. Meter operation remains unaffected during installation and configuration of I/O. The I/O Expander can be equipped with:

- 8 digital inputs and 8 digital outputs (4 Form A and 4 Form C solid state outputs)
- Pluggable connections for serial RS-232 communications
- 4 analog outputs that can replace the 4 Form A digital outputs. 2 analog output options are available, 0 to 20mA (scalable 4 to 20mA) and -1 to +1mA (scalable 0 to 1mA)

## Software Integration

With their extensive communication capabilities, the meters can be integrated into energy management or automation control systems.

ION Enterprise Operations Software  
ION 8000 series meters are compatible with our Windows 2000-based ION Enterprise operations software. The software is a comprehensive PC-based power monitoring, analysis and control system that lets you take advantage of all the advanced features of the ION 8000 series meters.

### ION Setup™ Software

The meters are further enhanced by ION Setup for Windows, a software solution that displays real-time data from your power monitoring devices and provides device configuration capabilities.

ION Setup lets you create a network of sites and devices, so that the meters are easy to find and the communication links are ready whenever you want to upgrade the firmware or make any configuration changes to your meters or network.

ION Setup is available to all ION 8000 series owners at no additional charge.

## Specifications

### Voltage Inputs

- Inputs: Va, Vb, Vc, Vref (9S/39S); Vab, Vcb, Vref (35S); Va, Vc, Vref (36S/76S)
- Form 9S/36S/39S/76S steady state: Standard 57-277 (±15%) VLN RMS†
- Form 9S/36S/39S/76S overload: Standard power supply: 120-277 (+/- 20%) VLN RMS†  
Low Voltage power supply: 57.7-69.3 (+/- 20%) VLN RMS†
- Form 35S steady state: 120-480 (+/-15%) VLL RMS†
- Form 35S overload: 120-480 (+/-20%) VLL RMS for 6 hrs max†

## Measurement Specifications (at 25°C / 77°F)

Parameter	Accuracy ± (%Reading + %Nominal Current#)
Voltage (L-L) (L-N)	0.1%
Frequency (47 - 63Hz)	±0.01Hz
Current (I1, I2, I3)	0.1% + 0.002%
Current (I4)	0.4%
kW, kVAR, kVA (Unity PF)	0.2% + 0.001%
kW, kVAR, kVA (±0.5 PF)	0.3% + 0.003%
kWh, kVARh, kVAh	Class 0.2*
Power Factor at Unity PF	0.5%
Harmonics (to 63rd)**	1%
Harmonics (to 40th)	IEC 61000-4-7
K Factor	5%
Crest Factor	1% Full Scale

# Nominal current: standard = 5A; Extended Current Range or Low Current option = 1A

\* Refer to Compliance section on page 7

\*\* On ION 8400 and ION 8500 meters only; ION 8300 to 31st

Display resolution meets or exceeds accuracy.

## User Programmable Log Capacity

Example Log Configurations:

	ION 8300		ION 8400		ION 8500			
Event	500 Events		500 Events		500 Events			
Data	85 days <sup>A</sup>	340 days <sup>B</sup>	0.5 years <sup>A</sup>	2 years <sup>B</sup>	1 year <sup>A</sup>	4 years <sup>B</sup>	280 days <sup>A</sup>	3 years <sup>B</sup>
Waveform	-		-		6 <sup>C</sup>	6 <sup>C</sup>	24 <sup>D</sup>	24 <sup>D</sup>

<sup>A</sup> 16 parameters recorded every 15 minutes

<sup>B</sup> 16 parameters recorded hourly

<sup>C</sup> on each of 6 channels at 128 samples per cycle for 14 cycles

<sup>D</sup> on each of 6 channels at 16 samples per cycle for 96 cycles

- Dielectric withstand: 2500V RMS, 60Hz for 1 min. (ANSI C12.1-1995/C12.16-1991/C12.20-1998)
- Surge withstand: 6kV peak (1.2/50us) voltage surge L-L and L-GND (IEC 255-4)  
ANSI/IEEE C37.90.1-1989 SWC and Fast Transient Common and transverse modes. ANSI C62.41
- Impedance: 5M Ohms/phase

### Current Inputs

- Low Current option: Start at 0.001A, accurate from 0.01 - 10A RMS. Meets ANSI Class 10 and IEC 60687 In=1A or 2A, Imax=10A. Overload 50A RMS for 1 second, non-recurring.
- Standard: Start at 0.005A, accurate from 0.05 - 20A, overrange to 50A RMS. Meets ANSI Class 10 or 20 and IEC 60687 In=5A, Imax= 20A.
- Extended Current Range option: Start at 0.001A, accurate from 0.01 - 24A RMS. Meets ANSI Class 10 or 20 and IEC 60687 In=1A, 2A or 5A, Imax=20A. Overload: 500 RMS for 1 second, non-recurring
- Surge withstand: 6kV peak (1.2/50us) voltage surge L-L & L-GND Common and Transverse modes
- Burden: Low current switchboard - 0.05VA per phase at 1A; Standard switchboard - 0.20VA per phase at 5A; All socket mounts - 0.05VA per phase at 5A

### Power Supply

#### Standard Power Supply, 120-277VAC

- Type: 3-Phase powered from voltage sensing inputs
- Burden: Max, 4W, 6.6VA/phase
- Form 9S/39S, 36S/76S: 120-277 -15%/+20% VLN RMS, 47-63Hz
- Form 35S: 120-480 (-15%/+20%) VLL RMS, 47-63Hz
- Ride-through: Min: 100ms 6 cycles at 60Hz at 96VAC
- Surge withstand: 6kV/0.5kA peak (100kHz Ring Wave) — ANSI C62.41 6kV/3kA peak (1.2/50-8/20us) voltage surge L-L and L-GND ANSI C62.41

#### Standard (Low Voltage) Power Supply, 57-70VAC

- Type: 3-Phase supply, drawing off voltage inputs
- Burden: Typical: 3W, 5VA/phase, 3-Phase operation Max: 4W, 6.6VA/phase, 3-phase operation
- Form 9S/36S/39S/76S: 57-70 (-15%/+20%) VLN RMS, 47-63Hz
- Form 35S: Unavailable
- Ride-through: Min 100ms or 6 cycles 60Hz at 46VAC
- Surge withstand: 6kV/0.5kA peak (100kHz Ring Wave) — ANSI C62.41, 6kV/3kA peak (1.2/50-8/20us) voltage surge L-L and L-GND ANSI C62.41

**Auxiliary Power Pigtail, 65-120VAC**

- Type: 1-Phase supply, powered through external cable with Grounded U-Plug
- AC: 65-120 (+/- 15%) VLN RMS, 47-63Hz  
DC: 80-160 (+/- 20%) VDC
- Burden: Typical: 10VA, Max: 20VA
- Ride-through: Min: 100ms 6 cycles 60Hz at 46VAC
- Surge withstand: 6kV/0.5kA peak (100kHz Ring Wave)  
ANSI C62.41 6kV/3kA peak (1.2/50-8/20us)  
voltage surge L-L and L-GND ANSI C62.41

**Auxiliary Power Pigtail, 160-277VAC**

- Type: 1-Phase supply, powered through external cable with Grounded U-Plug
- AC: 160-277 (+/- 20%) VLN RMS, 47-63Hz  
DC: 200-350 (+/- 20%) VDC
- Burden: Typical: 10VA, Max: 20VA
- Ride-through: Min: 100ms 6 cycles, 60Hz at 96VAC
- Surge withstand: 6kV/0.5kA peak (100kHz Ring Wave)  
ANSI C62.41 6kV/3kA peak (1.2/50-8/20us)  
voltage surge L-L and L-GND ANSI C62.41

**Environmental Conditions**

- Operating temp: -40°C to 85°C (-40°F to 185°F)
- Display operating temp: -20°C to 60°C (-4°F to 140°F)
- Storage temp: -40°C to 85°C (-40°F to 185°F)
- Humidity: 5% to 95% non-condensing

**Digital Inputs**

- 8 inputs: S1-S8, SCOM (through I/O Expander). Self-excited, dry contact sensing, no external voltage required. +30VDC differential between SCOM and S1 through S8 inputs. Or 24-130VDC externally excited.
- Minimum pulse width: 20ms
- Maximum input transition rate: 50 transitions/second
- Scan time: 20ms
- Timing resolution: 1ms, with 2ms accuracy
- Isolation: 1000V RMS, 60Hz for 1 minute to meter
- 3 additional internal inputs available through optional on-board I/O

**Solid State Outputs**

- 8 solid state outputs: C-1, C-2, C-3, C-4 (Form C) - through I/O Expander A-1, A-2, A-3, A-4 (Form A) - supported through I/O Expander
- Max. load voltage: 200VAC/DC\*
- Max. load current: 100mA
- On resistance: 30 Ohms (typical), 50 Ohms (max)
- Off resistance: 400M Ohms (min)
- Isolation: 3750V RMS, 60Hz for 1 minute to meter  
1000V RMS, 60Hz for 1 minute (between outputs)
- Update rate: 20ms
- Maximum output transition rate: 50 transitions/s
- 4 additional internal outputs available through optional on-board I/O

**Analog Outputs**

- 4 analog outputs: Supported through I/O Expander Output range: 0 to 20mA (scaleable from 4 to 20mA) or -1 to +1mA (scaleable from 0 to 1mA)
- Max. load: 500 Ohms (0 to 20mA), 10K Ohms (-1 to +1mA)
- Isolation: 3750V RMS, 60Hz for 1 minute to meter  
2000V RMS, 60Hz for 1 minute
- Accuracy: +/- 0.3% (% of Reading) at 23° C
- Accuracy drift: 100ppm/° K
- Resolution: 12 bits
- Update rate: 1 second

**Packaging**

- Socket meters: Forms 9S, 35S, 36S, 39S, 76S (ANSI C12.10-1997)
- Switchboard case: (FT-21 style) Forms 9, 35, 36
- Sealing/Cover: ANSI C12.1-1995/ANSI C12.10-1997/ANSI C12.16-1991
- Weatherproof: Dustproof, raintight (as per UL50-1987 raintightness test)
- Base finish: Reinforced plastic UV and Corrosion resistant (Class II)
- Cover finish: Polycarbonate, UV and Corrosion resistant (Class II)

**Shipping**

- Switchboard format: 15lbs / 6.8kg; 12 x 12 x 15.5in; 30.48 x 30.48 x 33.97cm
- Socket format: 8lbs / 3.7kg; 10.5 x 10.5 x 17in; 26.67 x 26.67 x 43.18cm

**Communications****Serial ports (Via breakout cable or I/O box)**

- RS-232E (DTE) and/or RS-485 (shielded twisted pair)
- Duplex: Full (RS232E), Half (RS485)
- Isolation: Optical

**Internal Modem**

- Interface: 33.6Kbps internal modem
- Duplex: Half
- Data rate: 300bps-33.6kbps (automatic data rate detection is supported)
- Interface: RJ11 (Tip and Ring), or RJ31
- Governmental approvals: FCC Part 68 (USA), Industry Canada CS-03 (CAN)

**Infrared Data Port**

- Interface: ANSI C12.13 Type 2 Optical Port
- Baud rates: 300-19200bps
- Duplex: Half
- Protocols: ION 2.0, Modbus RTU, DNP 3.0
- Location: Front of Meter

**Ethernet Port**

- Protocols: TCP/IP, Telnet, ION, Modbus TCP
- Interface: IEEE 802.3-1993, ISO/IEC 8802-3:1993 (Ethernet) 10BASE-T or 10Base-FL (optional)
- 10Base-T:
  - Cabling: Unshielded twisted pair cable, 0.5mm (24 AWG), max. length 100 meters
  - Connector: RJ45
  - Data rate: 10Mbps, half duplex
- 10Base-FL: (Socket Form Factor only)
  - Cabling: Fiber optic cable, 62.5/125um nominal, wavelength 850nm, max. length 2000 meters
  - Connector: ST (male)
  - Isolation: Optical
  - Length: 68.6mm (27")
  - Data rate: 10Mbps

**IRIG-B**

- Accuracy: +/- 1ms
- Format: IRIG-B00x format (unmodulated IRIG-B time code)
- Nominal voltage: 5 Vdc +/- 10%
- Maximum voltage: 8 Vdc
- Connection: captured wire (E8, F8, G8 form factors) or twisted pair (other form factors).
- Standards compliance: IRIG Standard 200-98 - IRIG Serial Time Code Formats

**Display**

- Type: FSTN Liquid Crystal Display (LCD)
- Resolution: 240 x 67 pixels
- Size: 72 (H) x 32 (W) mm
- Temperature: Operational from -20°C to +60°C
- Backlight: LED (Green)
- Backlight timeout: 0 (always on) - 120 min
- Standards compliance: Exceeds ANSI C12.16-1991, IEC 60687

**Standards Compliance****Accuracy and Approvals**

- Independent certification to C12.20-1998, class 0.2 by MET Labs
- US approvals include California ISO, ERCOT, and New York State
- Industry Canada approved (AE-0924)
- Independent certification to IEC 60687 - Class 0.2S by KEMA
- Approved to MARIA Code of Practice 4 for New Zealand
- Certified by Comision Federal de Electricidad and LAPEM in Mexico, and INTI in Argentina
- All inputs pass ANSI/IEEE C37.90-1989 surge withstand and fast transient tests

**Safety/Construction**

- ANSI C12.20-1998 American National Standard for Electricity Meters 0.2 and 0.5 Accuracy Classes

**Electromagnetic Immunity**

- IEEE C.37-90.1-1989: IEEE Standard Surge Withstand Capability (SWC) Tests for Protective Relays and Relay Systems (ANSI)
- ANSI C12.20-1998: American National Standard for Electricity Meters 0.2 and 0.5 Accuracy Classes
- IEC1000-4-2 (EN61000-4-2/IEC801-2): Electrostatic Discharge (B)
- IEC1000-4-3 (EN61000-4-3/IEC801-3): Radiated EM Field Immunity (A)
- IEC1000-4-4 (EN61000-4-4/IEC801-4): Electric Fast Transient (B)
- IEC1000-4-5 (EN61000-4-5/IEC801-5): Surge Immunity (B)
- IEC1000-4-6 (EN61000-4-6/IEC801-6): Conducted Immunity
- ANSI C62.41: Surge Immunity

**Electromagnetic Emission**

- FCC Part 15 Subpart B, Class A: Class A Digital Device, Radiated Emissions

**Modem**

- FCC Part 68
- Industry Canada CS-03

**Miscellaneous**

- Optical Communications Port: ANSI C12.13-1991 Type 2

# Datasheet: ION® 8300 | 8400 | 8500

Some features are optional.

To identify standard and optional features, please see the 'Product Order Forms' at [www.pwrm.com](http://www.pwrm.com).

Features and Options List	ION 8300	ION 8400	ION 8500
<b>Power, Energy, and Demand</b>			
Voltage/current per phase, average, unbalance	■	■	■
Power: real, reactive, apparent, power factor, frequency	■	■	■
Energy: bi-directional, total, import, export, net	■	■	■
Demand: block, rolling block, thermal, predicted	■	■	■
<b>Power Quality</b>			
Sag/Swell monitoring	■	■	■
Symmetrical components: zero, positive, negative	■	■	■
Transient detection, microseconds			65
Harmonics: individual, even, odd, total up to	31 <sup>st</sup>	63 <sup>rd</sup>	63 <sup>rd</sup>
Harmonics: magnitude, phase and inter-harmonics			40 <sup>th</sup>
Sampling rate, maximum samples per cycle	128	128	256
Flicker, (harmonics to EN50160, IEC 6100-4-7/4-15)			■
Configurable for IEEE 519 - 1992, IEEE159, SEMI			■
Uptime in number of nines	■	■	■
<b>Logging and Recording</b>			
Standard memory capacity	1MB	2MB	4MB
Min/max logging for any parameter	■	■	■
Historical logs, maximum # of channels	32	320	800
Waveform logs, maximum # of cycles			96
Timestamp resolution in seconds	0.001	0.001	0.001
GPS time synchronization	■	■	■
<b>Communications and I/O</b>			
RS-232/485 ports	1	1	1
RS-485 ports	1	1	1
Ethernet ports	1	1	1
Infrared optical port ANSI Type 2	1	1	1
IRIG-B port	1	1	1
Internal modem	1	1	1
DNP 3.0 through serial, modem, and I/R ports	■	■	■
Modbus RTU slave on serial, modem and I/R ports	■	■	■
Modbus RTU Master on serial ports		■	■
Modbus TCP through Ethernet	■	■	■
EtherGate, data transfer between Ethernet & RS-485	■	■	■
ModemGate, data transfer between internal modem & RS-485	■	■	■
MeterM@il, logged data and alarms via e-mail	■	■	■
WebMeter, on board web server	■	■	■
Internal KYZ outputs	4	4	4
Internal Form A inputs	3	3	3
External analog outputs	4	4	4
External digital status inputs/counter	8	8	8
External solid state outputs	8	8	8
<b>Setpoints, Alarming, and Control</b>			
Setpoints, minimum response time	1 second	1/2 cycle	1/2 cycle
Setpoints, number of	65	65	65
Math, logic, trig, log, linearization formulas	■	■	■
Single & multi-condition alarms	■	■	■
Call-out on alarms	■	■	■
Dial-out on outage	■	■	■
<b>Revenue Metering and Standards</b>			
ANSI C12.16 accuracy compliant	■	■	■
ANSI C12.20 0.2 compliant	■	■	■
IEC 60687 0.2S compliant	■	■	■
IEC 60687 accuracy class 0.5S compliant	■	■	■
ANSI class 10; IEC 1A, 2A nominal, 10A max.	■	■	■
ANSI class 10, 20; IEC 5A nominal, 20A max.	■	■	■
ANSI class 10, 20; IEC 1A, 2A, 5A nominal, 20A max.	■	■	■
MV-90 on serial, modem & Ethernet ports (if present)	■	■	■
Multi-year scheduling: hourly activity profiles	■	■	■
Transformer/line loss compensation	■	■	■

## Meet the World Leader

Power Measurement is the leading provider of enterprise energy management systems for energy suppliers and consumers worldwide. Our ION® web-ready software and intelligent electronic devices comprise a complete, real-time information and control network that supports billing for complex energy contracts and helps improve power quality, reduce energy costs and keep operations running enterprise-wide, 24 hours a day. Our reputation for unparalleled value, quality and service is based on over two decades of innovation and experience.

### Worldwide Headquarters

2195 Keating Cross Rd.  
Saanichton, BC, Canada V8M 2A5  
Tel: 1-250-652-7100 Fax: 1-250-652-0411  
email: [sales@pwrm.com](mailto:sales@pwrm.com)

### Europe

Schulstrasse 6  
91320 Ebermannstadt, Germany  
Tel. +49 (0) 9194-724 765  
Fax +49 (0) 9194-724 766  
email: [pme@pwrm.com](mailto:pme@pwrm.com)

For the most up to date information, go to



**POWER  
MEASUREMENT**

drive energy performance™

[www.pwrm.com](http://www.pwrm.com)

Toll free 1-866-466-7627

USA And Canada only

Revision Date: October 2004

© 2004 Power Measurement. Printed in Canada 70100-0120

ION, ION Enterprise, ION 8300, ION 8400, ION 8500, MeterM@il, WebMeter, EtherGate, ModemGate are trademarks of Power Measurement. All other trademarks are property of their respective owners. Any reproduction or re-transmission in whole or in part of this work is expressly prohibited without the prior consent of Power Measurement. Information contained herein is subject to change without notice. Any technical assistance provided by this Power Measurement document for system design or configuration shall be deemed to be a proposal and not a recommendation. The responsibility for determining the feasibility of such proposals rests with the original purchaser and should be tested by the original purchaser.

YOUR LOCAL  
REPRESENTATIVE



Certificate No. 002188